

FCI FlexMASter® ST98 and ST98-L:

The Best Value in a
High Performance



FlexMASter® SERIES

Thermal Mass Flowmeter

for Gas Applications.



FlexMASter® ST98 Flowmeter Series | The new FCI FlexMASter ST98 Flowmeter Series sets the standard for value and performance with smart electronics in a rugged, economical package. The result is superior performance and application versatility for exceptional installed value. In today's complex process environment, where harsh conditions often exist, the FlexMASter Series is the ideal choice for precision gas flow measurement. Over 35 years of FCI experience in Thermal Dispersion flowmeter technology was applied in the development of the FlexMASter Series.

Smart Electronics | With a smart microprocessor-based design, the intelligent FlexMASter ST98 is ideal for a wide range of gas flow measurement applications. The ST98's electronics are housed in a NEMA/CSA Type 4X or optional FM/CSA/CENELEC system approved explosion-proof electrical enclosure that features ready access to wiring terminals in the dual sided design. The electronics accept universal AC (85 to 260 volts) or 24 Vdc input power. The output signal can be field programmed for 4-20mA, 0-5 Vdc, or 0-10 Vdc. An RS-232C serial port provides an interface to FCI's FC88 Pro-programmer, a computer or any ASCII-oriented terminal.

HART® Field Communications Protocol | The industry standard for digitally enhanced 4-20mA communications with smart field instruments is now available as an option with the ST98 FlexMASter Series. HART's enhanced two-way communication significantly improves plant information management by providing solutions to today's business challenges and yielding reported



Optional LCD display

substantial cost savings for initial installation/commissioning of \$400 to \$500 per instrument and annual maintenance/ operations savings of \$100 to \$200 per instrument.

HART technology benefits include:

- The only "open" communications protocol of its type and in "defactor" industry standard
- Easy access to variables, diagnostics and calibration data
- No risk solution for maintenance and operations personnel by providing parallel operation of the 4-20 mA instrument signal and HART's enhanced two-way field communication capability
- Multidrop capability of several field instruments substantially reduces installation costs

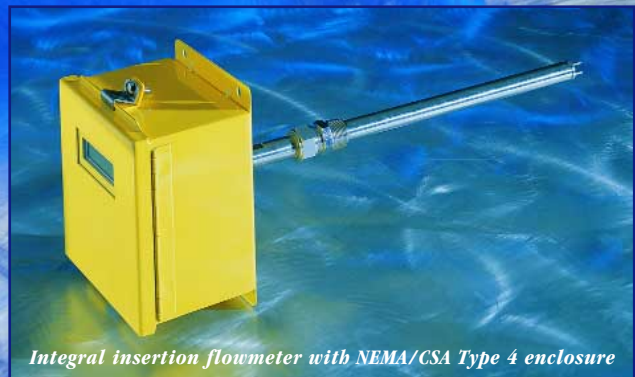
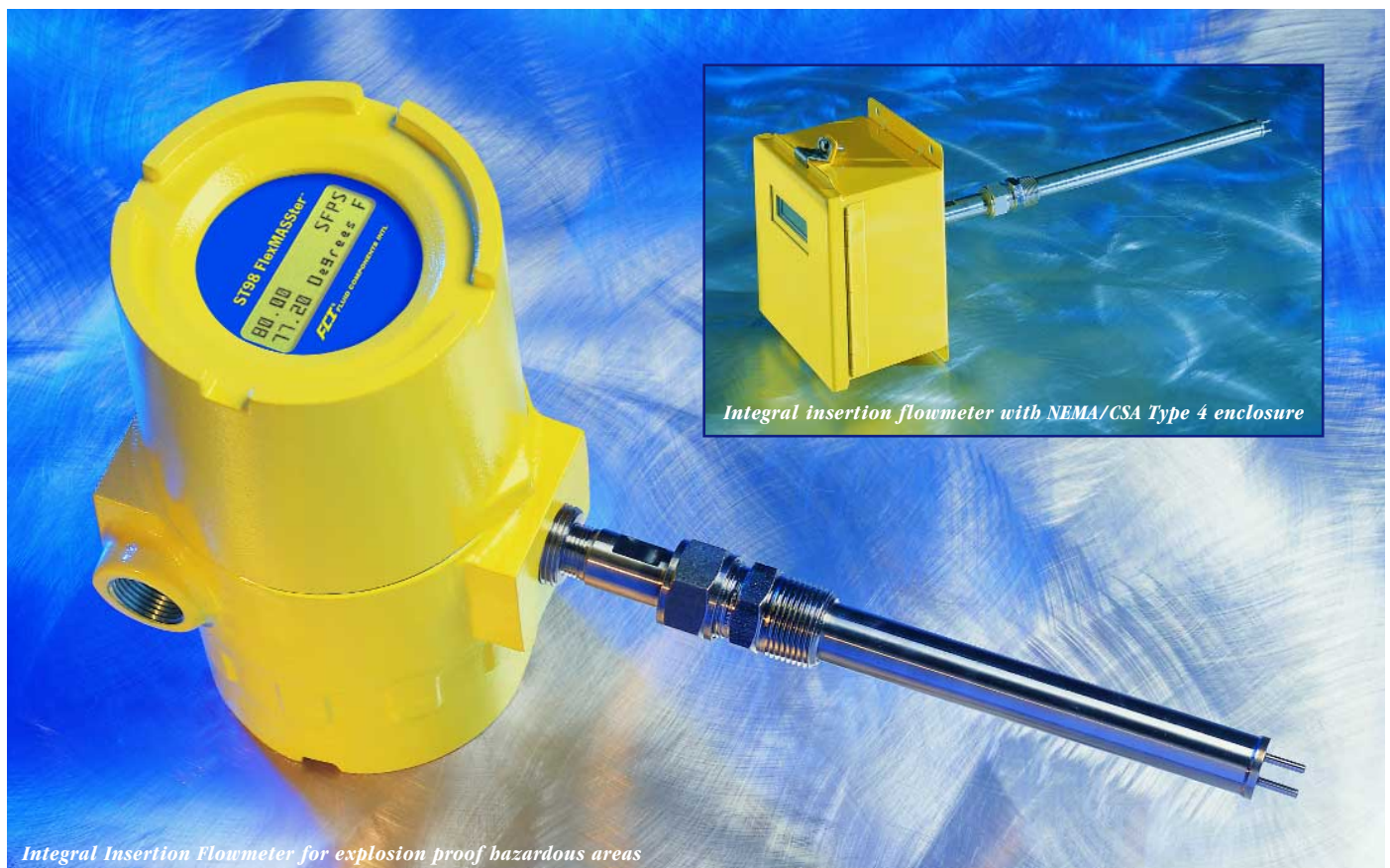

Integral insertion flowmeter with NEMA/CSA Type 4 enclosure

Integral Insertion Flowmeter for explosion proof hazardous areas

Direct Mass Flow Measurement Performance | The FlexMASter ST98 Flowmeter Series features FCI's no-moving parts mass flow element design. It simplifies mass flowmetering with a single process penetration, eliminating temperature / pressure transmitters and the density calculation required with other non-mass flowmeter technologies, such as differential pressure, vortex or turbine. This results in superior accuracy, response time, and repeatability. In today's complex process control schemes, accurate gas flow measurement is essential for product consistency and quality and safe operation of process plants. FCI has partnered with VORTAB® to optimize performance and overcome installation effects in short straight runs. The FlexMASter ST98 Series features an accuracy of $\pm 1\%$ of reading plus 0.5% of full scale, and repeatability of 0.5% of reading.

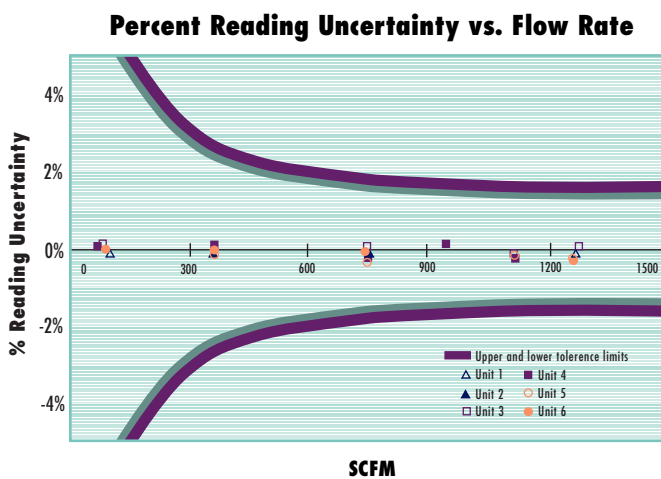

Air flow in 6 inch schedule 40 pipe (typical factory calibration results)

The air flow calibration range of the insertion unit is from 0.75 to 600 SFPS (0.21 to 172 NMPS) at 70°F (21°C) and 14.7 psia [1 bar (a)]. The ST98-L inline unit air-flow calibration range is from 0.006 to 1,850 SCFM (0.01 to 3,140 NCMH) at 70°F (21°C) and 14.7 psia [1 bar (a)]. The turndown ratio is factory preset per application from a minimum of 10:1, to a maximum of 100:1 and is field adjustable within the calibrated range.

Applications Versatility | With its innovative design, the FlexMASter Flowmeter Series is ideal for a wide range of rigorous applications in:

- › Wastewater aeration and digesters
- › Landfill vapor or biogas recovery
- › Natural gas or methane monitoring
- › Compressed air metering
- › Heavy industrial HVAC systems
- › Nitrogen blanketing
- › Combustion air

Easy to install, Easier to Use | Field technicians find that the installation of the FlexMASter ST98 Series flowmeter is a simple, rapid process. No special or custom tools are required.

The FlexMASter ST98 Series is factory-calibrated and tested prior to shipment. FCI technicians set the instrument's units of measure and provide precise adjustment of zero and full scale for specific process applications.

By designing the FlexMASter with nonvolatile memory, FCI helps prevent the loss of valuable application and totalized flow data. Power outages or surrounding equipment failures need never again mean a loss of critical flow data. *Your flow data is truly safe with FCI.*

Comprehensive diagnostics, field-adjustable settings and HART protocol are available with the FlexMASter ST98 Series. The FCI FC88 Programmer is quickly connected to the FlexMASter's RS-232C serial port via an RJ11 phone jack. The serial port provides access to the FlexMASter's flow computer. Password protection offers security against unauthorized access. With the FlexMASter ST98 Series, built-in testing and diagnostic capabilities ensure accurate and reliable flowmeter performance. On-command diagnostics include: out-of-range detection, output loop and sensor element continuity verification, and a forced calibration output.



Field wiring terminations (bottom) and circuit board access are in separate enclosure chambers.

Exceptional Reliability | The FlexMASter ST98 and ST98-L system's unique design is based on FCI's advanced Thermal Dispersion technology flow element, which has no-moving parts for exceptional reliability, trouble-free operation in the dirtiest of environments and a well-known reputation for long-life. There are hundreds-of-thousands of FCI instruments at work today around the world -- ensuring process quality and protecting valuable equipment.

The FlexMASter ST98 and ST98-L meter's flow element is highly resistant to corrosion. It features an all-welded 316 stainless steel construction. For excessively corrosive applications, Hastelloy C is available as an option for all wetted surfaces.

Explosion-Proof Flowmeter | The FlexMASter ST98 and ST98-L's flow element and transmitter are manufactured with high grade industrial components for use over a wide temperature range and in harsh environments. The standard aluminum enclosure is explosion-proof. It is rated for hazardous location use (Class I and II, Division 1 and 2, Group B, C, D, E, F and G; and EEx d IIB) and resists the effects of weather and corrosion (NEMA/CSA Type 4X and equivalent to IP 66). The flow transmitter can be remotely mounted as an option. FlexMASter is system approved by leading agencies including FM, CENELEC and CSA.

Process Connections | The standard process connection for the ST98 insertion flow element is 3/4 inch male NPT stainless steel compression fitting with either adjustable Teflon ferrule,

rated to 150 psig [10 bar(g)] and 200°F [93°C], or stainless steel ferrule, rated to 250 psig [17 bar(g)] and 500°F [260°C]. Three different field adjustable probe lengths for the insertion flowmeter are available. Male NPT threaded or flanged fixed insertion lengths also can be specified. The standard process connections for the ST98-L inline flow element are 3/4 inch female NPT on the 1 inch diameter tubing assembly and male NPT on the 1 1/2 to 2 inch diameter pipe assemblies (flanged optional).

Global Approvals | The FlexMASter ST98 standard enclosure resists the effects of weather and corrosion (NEMA/CSA Type 4X and equivalent to IP66) and is rated for Class I and II, Division 2, areas (pending). An optional aluminum enclosure is explosion-proof and rated for hazardous location use (Class I and II, Division 1 and 2, Groups B, C, D, E, F and G; and EEx d IIB) while resisting the effects of weather and corrosion (NEMA/CSA Type 4X and equivalent to IP 66). Approvals include FM, CENELEC, and CSA, as well as CE Mark.

FCI's Instrument User's Protection Plan

Guaranteed Performance. FCI guarantees the performance of its product line in accepted applications or your money back.

1-Year Warranty. The FCI ST98 Series is warranted against faulty materials and workmanship for one year from the date of delivery.

Customer Service. FCI provides prompt 24-hour customer service including expedited field service, start-up and commissioning assistance, repair support, and toll-free factory service.



FlexMASter ST98 Series Mass Flowmeter General Specifications

Instrument

Flow Range

ST98 Insertion Flow Element: 0.75 to 600 SFPS [0.21 to 172 NMPS]

ST98L Inline Flow Accessory: 0.0062 to 1850 SCFM

[0.01 to 3,140 Nm³/h]

-- Air at standard conditions; 70°F [21.1°C] and 14.7 psia [1.01325 bar (a)].

Media: All gases that are compatible with the flow element material.

Accuracy

Flow: ±1% reading + 0.5% full scale standard accuracy

Temperature: ±2°F (display only, flow rate must be greater than 5 AFPS)

Repeatability

Flow: ±0.5% reading

Temperature: ±1°F (flow rate must be greater than 5 AFPS)

Turndown Ratio:

Standard: Factory set and field adjustable from 10:1 to 100:1 within calibrated flow range.

Temperature Compensation:

Standard: ±30°F [±1°C]

Optional: ±100°F [±38°C]

Agency Approvals: FM, CSA, CENELEC, T4 Rated (System Approval), CE Mark (EMC Directive 89/336/EEC); CPA and INMETRO pending.

Calibration: Performed on NIST traceable equipment.

Flow Element

Material of Construction: All-welded 316 stainless steel; Hastelloy C optional.

Operating Pressure: 0 to 250 psig [0 to 17 bar (g)], derated with Teflon ferrule.

Operating Temperature: Process temperature -40°F to 350°F [-40°C to 177°C]; integral electronics rated to 140°F [60°C].

ST98 Insertion Flow Element

Process Connection: 3/4 inch male NPT stainless steel compression fitting; adjustable Teflon ferrule; 150 psig [10 bar (g)] and 200°F [93°C] max., or metal ferrule; 250 psig [17 bar (g)] and 350°F [177°C] max.; thread-on flange optional.

Insertion Length: Field adjustable lengths: 1 to 6 inch [25 to 152 mm], 1 to 12 inch [25 to 305 mm] or 1 to 21 inch [25 to 533 mm]; custom lengths optional.

ST98L Inline Flow Tube: Insertion flow element is threaded and keyed in an inline flow tube; calibrated and supplied as a unit. Accessories include low flow injection tubes and built-in VORTAB® flow conditioners for optimum low flow rangeability and performance.

Size: 1 inch diameter tubing; 1 inch, 1 1/2 inch or 2 inch schedule 40 pipe.

Length: 9 nominal diameters

Process Connection: Female NPT on 1 inch tubing; male NPT on 1 inch, 1 1/2 inch and 2 inch schedule 40 pipe.

Option: Flanges

Local Enclosure:

Standard: NEMA/CSA Type 4X (equivalent to IP66) and Division 2 (Ex n)

Option: Aluminum rated for hazardous location use Class I and II, Division 1 and 2, Group B, C, D, E, F, G (previously referred to as NEMA 7) and EEx d IIC and resists the effects of weather and corrosion.

Remote Transmitter Configuration: Transmitter may be mounted remotely from flow element using interconnecting cable (up to 500 feet [152 m]).

Flow Transmitter

Operating Temperature: 0 to 140°F [-18 to 60°C]

Input Power: 85 to 265 Vac or 22 to 30 Vdc;

7 watts maximum, 230 mA maximum

Output Signal

Current: 4 to 20 mA, 700 ohms maximum load

Voltage: 0-10 Vdc, 0-5 Vdc, 1-5 Vdc, 100K ohms minimum load

Note: Output signal is isolated from input power on AC powered unit only.

Analog Fault Indication: Per NAMUR NE 43 guideline: Field selectable high (≥ 21.6 mA) or low (≤ 3.75 mA).

Communication Port: EIA-232 [RS-232C]

HART Field Communications Protocol: optional

Display (optional): 2 line/16 character per line, indicating flow rate and process temperature and/or totalized flow.

Programmer (optional): Hand held plug-in interface (model FC88).

Remote Enclosure (optional):

Standard: NEMA/CSA Type 4X (equivalent to IP66) and Division 2 (Ex n)

Option: Aluminum rated for hazardous location use Class I and II, Division 1 and 2, Group B, C, D, E, F, G (previously referred to as NEMA 7 and EEx d IIC) resists the effects of weather and corrosion.

Flow Conditioning (optional):

VORTAB® Flow Conditioner: Meter Run (VMR), Insertion Sleeve (VIS) or Field Kit (VFK)



Mounting Bracket: standard feature with remote assemblies.

FlexMASter Model ST98 Insertion Flowmeters

Integral Transmitter

NEMA 4 Carbon Steel (Standard) or NEMA 4X, Aluminum (Optional)

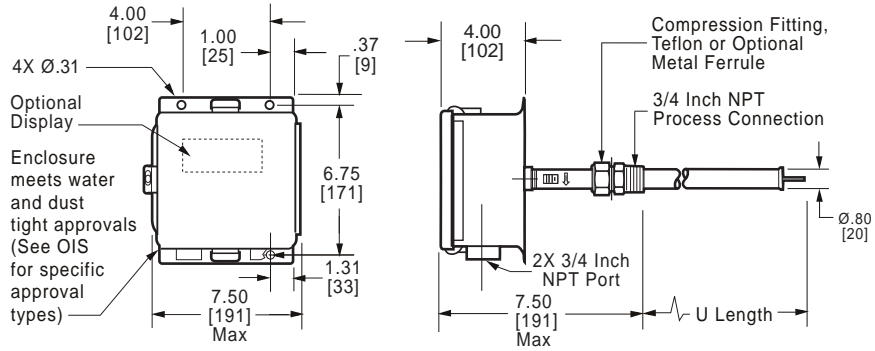

Hazardous Locations, Aluminum (Optional)

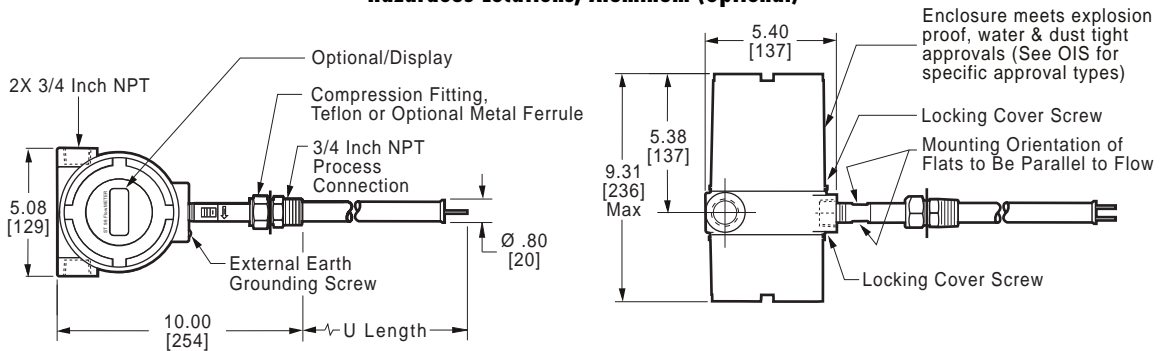

Remote Transmitter

Flow Element: Hazardous Locations, Aluminum (Optional)

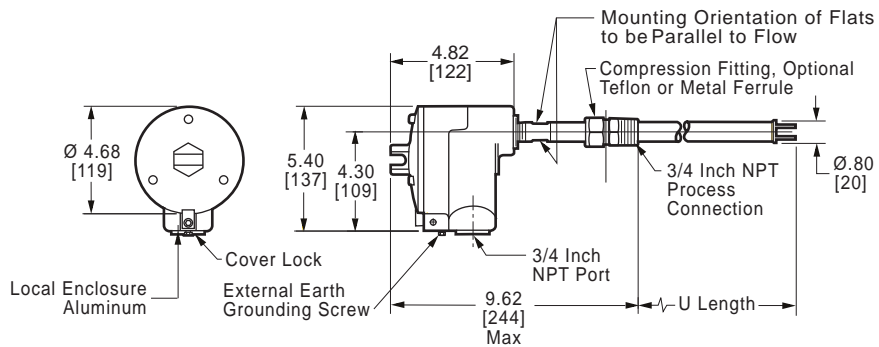

Enclosure: NEMA 4 Carbon Steel or NEMA 4X Aluminum

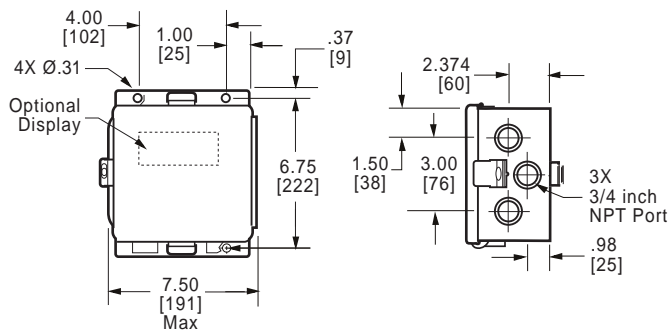

Enclosure: Hazardous Locations

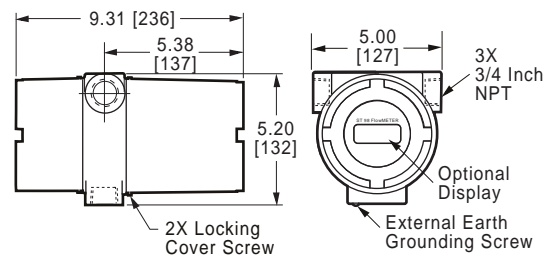

FlexMASter Model ST98L Inline Flowmeters

Integral Transmitter NEMA 4 Carbon Steel (Standard) or NEMA 4X, Aluminum (Optional)

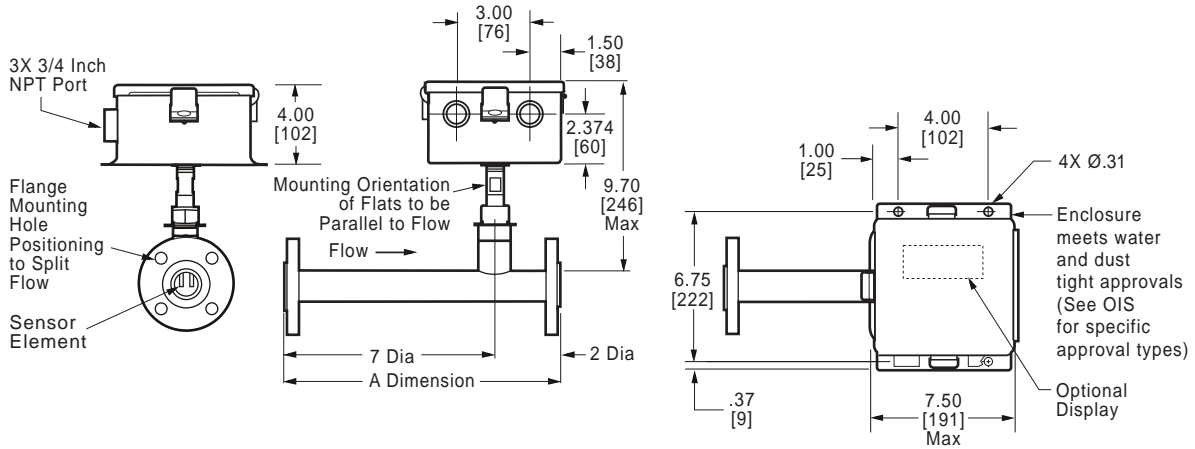

Hazardous Locations, Aluminum (Optional)

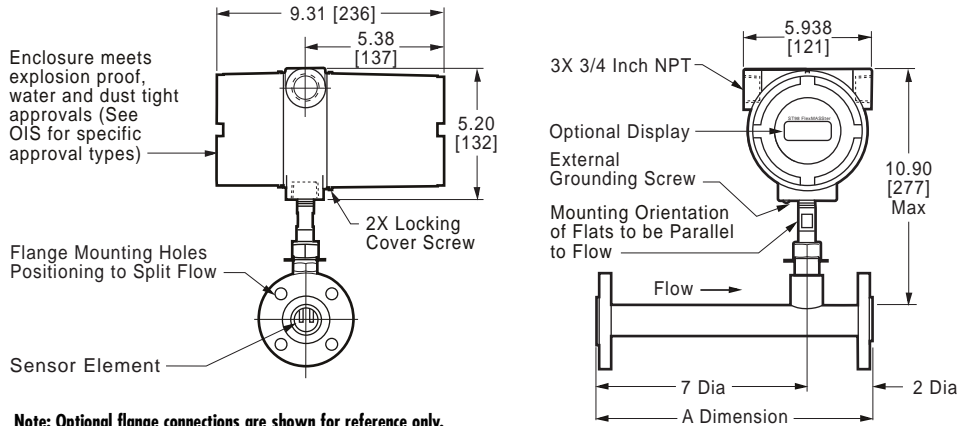

Note: Optional flange connections are shown for reference only. Standard process connection is male NPT.

Remote Transmitter Flow element: Hazardous Locations, Aluminum (Optional) Transmitter: See Remote Configurations for ST98 Insertion Flowmeter

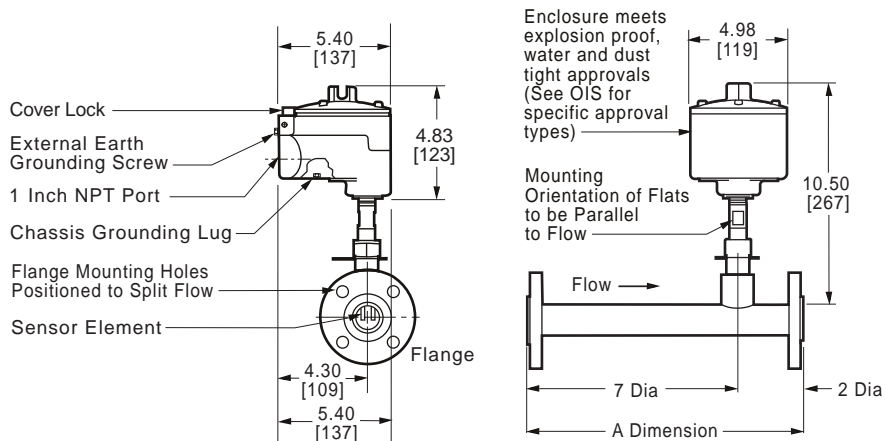



Test and Calibration Laboratory Fluid Components Intl maintains an extensive, instrument test and calibration laboratory at its headquarters in San Marcos, California. Utilizing the latest in advanced, computerized data acquisition systems and calibration test equipment, this facility permits comprehensive product development, testing, and calibration. Any FCI product can be calibrated in accordance with customer specifications. Laboratory standards are maintained with NIST (National Institute of Standards and Technology) traceable Cavitating Venturis (CVs) and precisely calibrated, pressure and temperature corrected turbine flowmeters.

Combustible and non-combustible gas calibration flow stands allow for the calibration of FCI products in a wide range of gases and gas mixtures from flow stand line sizes as small as 1/8 inch to 30 inches [3 to 760 mm] in diameter. A variety of flow profiles

from laminar to turbulent to conditioned are generated to duplicate actual field conditions. Flow rates from 0 to 20,000+ SCFM [0 to 34,000 Nm³/h], velocities from 0 to 800 SFPS [0 to 240 NMPS], pressures from vacuum to 3000 psig [200 bar(g)], and temperatures from -100° to +900°F [-70° to +480°C] are available.

On-Site Calibration and Training In-situ calibration is available from FCI's Field Service engineers where precise test and calibration is accomplished in actual media conditions.

FCI's Training Department can provide on-site or at the factory Product Knowledge Workshops for our customers. The workshops cover installation, setup, and troubleshooting skills, and include hands-on exercises using real products, under actual operating conditions.

24 Hour Customer Service Access Available

NIST Net



FCI® **FLUID COMPONENTS INTL**
a limited liability company

Web: www.fluidcomponents.com | **Email:** info@fluidcomponents.com

1755 La Costa Meadows Drive, San Marcos, California 92069 USA | **Phone:** 760-744-6950 | **Toll free:** 800-854-1993 | **Fax:** 760-736-6250

European Office: Persephonstrat 3-01 5047 TT Tilburg, The Netherlands | **Phone:** 31-13-5159989 | **Fax:** 31-13-5799036

FCI is ISO 9001 certified/conformance to AS9000